

ADVCIIO

Advanced Digital Video Converter

User Manual

September 18, 2007



Copyright© 2004-2007 Thomson. All rights reserved.

Copyright Regulations

It is illegal for anyone to violate any of the rights provided by the copyright laws to the owner of copyright, except for fair use (mainly private noncommercial use). Also, in certain cases copying is prohibited with no exceptions. In no event shall Grass Valley be liable for any direct or indirect damages whatsoever arising from the use of captured materials.

Warranty

Your ADVC110 options are covered by a limited warranty when you register your Grass Valley product. This warranty is for a period of one year (or two years in European Union countries) from the date of purchase from Grass Valley or an authorized Grass Valley agent. This warranty applies only to the original purchaser of the Grass Valley product and is not transferable, Grass Valley warrants that for this period the product will be in good working order. Should our product fail to be in good working order, Grass Valley will, at its option, repair or replace it at no additional charge, provided that the product has not been subjected to misuse, abuse or non-Grass Valley authorized alternations, modifications and/or repair.

Proof of purchase is required to validate your warranty.

Grass Valley is not responsible for any lost profits, lost savings or other incidental or consequential damages arising out of the use of, or inability to use, this product. This includes damage to property and, to the extent permitted by law, damages for personal injury. This warranty is in lieu of all other warranties of merchantability and fitness for a particular purpose.

DANGER

The following conditions indicate the potential for serious bodily injury or loss of life.

Health precautions

In rare cases, flashing lights or stimulation from the bright light of a computer monitor display may trigger temporary epileptic seizures or loss of consciousness. It is believed that even individuals whom have never experienced such symptoms may be susceptible. If you or close relatives have experienced any of these symptoms, consult a doctor before using this product.

Do not use in environments requiring a high degree of reliability and safety

This product is not to be used in medical devices or life support systems. The characteristics of this product are not suited for use with such systems.

Protect against static electricity

An electrostatic discharge may damage components of this product. Do not directly touch any of the connectors or component surfaces.

Static electricity can be generated on clothing and on people. Before handling the product, discharge static electricity from your body by touching a grounded metal surface.

Do not disassemble

Do not remove the cover or modify the ADVC110. Fire, electric shock or malfunction may result. For internal inspection or repair, please contact your system integrator or Grass Valley directly.

Do not operate at other than the specified voltage

Do not operate at other than the specified voltages of AC 100–240V. Operation at other than the rated voltage may result in fire or malfunction.

Do not operate with an unofficial AC adapter

Do not operate with an unofficial AC adapter, or with a car power supply. Such operation may result in fire or malfunction.

Handle the IEEE1394 cable carefully

Do not place heavy objects on top of the cable, or place it near hot objects. Doing so may damage the cable and result in fire, electrical shock, or malfunction. Altering the cable, or excessively bending or pulling the cable may result in fire or electrical shock. If the cable is damaged, please contact your local retail outlet or Grass Valley directly.

CAUTION

The following conditions indicate the potential for bodily harm, damage to hardware or loss of data.

Do not pull on the FireWire cable when disconnecting from electrical outlet

When disconnecting the FireWire cable, pull on the plug, not the cable itself. Pulling on the cable can damage the cable and may result in fire or electric shock.

Do not touch AC adapter(optional) with wet hands

Do not disconnect or plug in the AC adapter(optional) when your hands are wet. Contact with water may result in electric shock, fire or damage.

Do not setup in an area that becomes hot

Do not setup in an area exposed to direct sunlight or near a heating apparatus. The heat can accumulate, causing burns, fire or damage. Also, the unit may become deformed or change color.

Do not setup other than the prescribed method

Do not setup in a manner other than prescribed. Do not use while wrapped in cloth or plastic. Heat can accumulate, causing burns, fire or damage.

If product will not be used for an extended period

If this product will not be used for an extended period of time, disconnect the AC adapter(optional) from the electrical outlet.

All cables used to connect peripherals and other devices must be shielded and grounded

Operation with cables, connected to peripherals and other devices, that are not shielded and grounded may result in failure of this product.

Product Notes

1. Unauthorized copying of a portion or the entirety of this product is prohibited.
2. The description and specifications of this product are subject to future change without notice.
3. The description of this product has been prepared to be as complete as possible. If the reader is aware of any questionable points, errors or omissions, please contact Grass Valley.
4. The company assumes no liability for the results of practical application, regardless of item (3) above.
5. Regardless of whether negligence occurs during usage, the company assumes no liability, even if there is a claim, for extraordinary, incidental or derivative loss, including the loss of profits, that arise during practical application of this product.

Chapter 1

Basic Instructions

The ADVC110 is a simple solution for converting your analog tapes, such as VHS and S-VHS, to DV in realtime. This manual guides you through the basics of analog/digital conversion. Package contents include:

- ADVC110 unit
- FireWire Cable (6 pin-6 pin)

QuickStart

If you want to jump right in and use the ADVC110, simply plug it in and follow these steps.



Info

If you are capturing PAL video, you need to change the DIP switch settings. For more info, see Setting DIP switches on page 16.



Caution

All cables used to connect peripherals and other devices must be shielded and grounded. Operation with cables, connected to peripherals and other devices, that are not shielded and grounded may result in failure of this product.

1. Insert the **FireWire** cable (6 pin - 6 pin) to the DV IN/OUT terminal on the rear panel, to connect the ADVC110 unit to your computer.

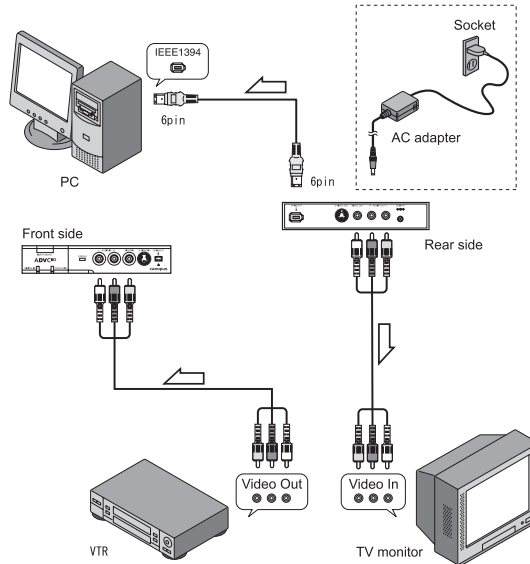

2. If you are capturing video from an analog video, make sure the ADVC110 is set to **Analog In** and that the video is connected to the unit's S-Video or composite ports on the front of the unit.

If you are exporting video to an analog video, make sure the ADVC110 is set to **Digital In** and that the video is connected to the unit's S-Video or composite ports on the back of the unit.

3. You can now open your editing application and begin capturing video.

ADVC110 Basics

The front of the ADVC110 contains inputs for composite, S-Video and DV. The DV input is a 4-pin FireWire port and can do both input and output.

Input Select button

The **Input Select** button on the top of the unit lets you toggle between **Digital In** and **Analog In** modes. A blue light signifies which mode the ADVC110 is using. The Input Select button will not work while the both status lights are blinking.

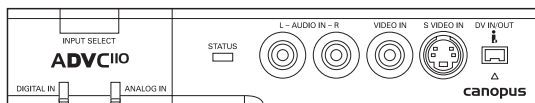

- **Digital In** - Indicates that the ADVC110 is ready to receive digital video.
- **Analog In** - Indicates that the ADVC110 is ready to receive analog video.

Status light

The **Status** light indicates separate things depending on which mode you are using.

- **Analog In** - The status light blinks when a Macrovision-protected signal is detected.
- **Digital In** - The status light blinks when the DV audio is set at 32kHz 12bit, which is used for 4-channel DV audio. See 4-channel mixing mode on page 17 for more information.



Info

Connected to a PC with an IEEE 1394 cable, ADVC110 can operate without the AC adapter. In other cases, use an official AC adapter (optional) for the power supply. In case the bus power is too low, the AC adapter is also required.

Connection Ports



Caution

All cables used to connect peripherals and other devices must be shielded and grounded. Operation with cables, connected to peripherals and other devices, that are not shielded and grounded may result in failure of this product.

The front panel of the ADVC110 has connection ports for both S-Video and composite input, as well as a 4-pin FireWire input/output port.

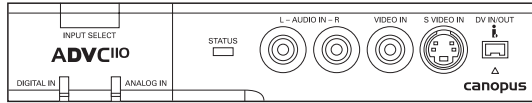

The back panel of the unit has ports for both S-Video and composite output, as well as a 6-pin FireWire input/output.

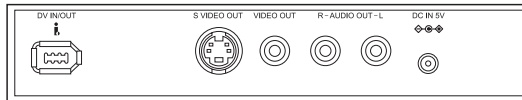

Select Input modes

ADVC110 has 2 INPUT modes; ANALOG IN and DIGITAL IN.

ANALOG IN mode

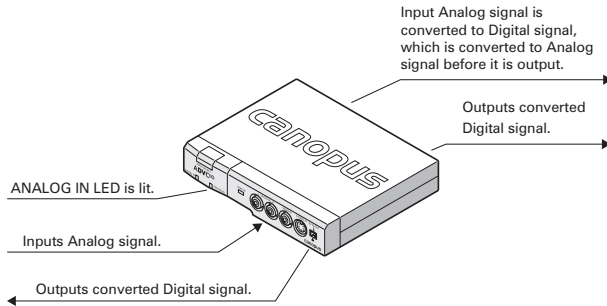

ADVC110 can output 2 DV signals.

However, if the unit is connected to your computer, the DV signal is output only to your computer. Even though you connect a device to the other port, DV signal IS NOT output to that port.

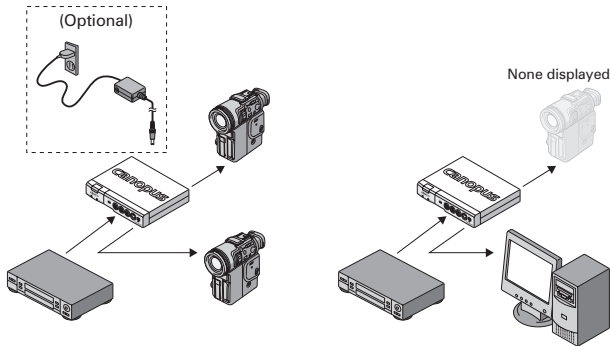

DIGITAL IN mode



Info

There are few PC that can control multiple devices, do not use the ADVC110 in the Hub connection where multiple DV signals are input simultaneously).

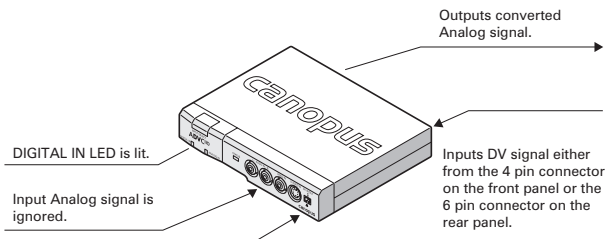

How to switch modes

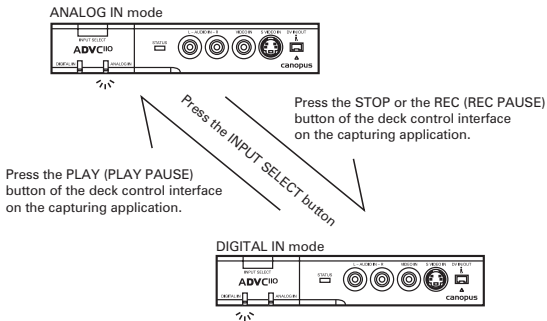

Color Bar Output

Press and hold the INPUT SELECT button for three seconds to output color bars from the Analog output. Input Analog and Digital signals are ignored, while the audio is muted.

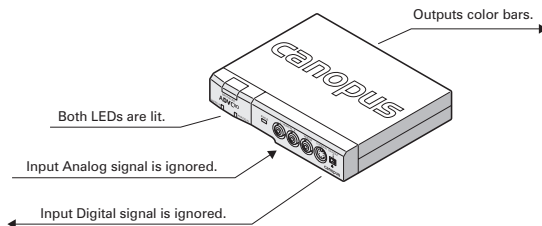

Audio Capturing mode

In the normal operation of the INPUT modes, audio stream will not be output while the video signal is not input. If you want to capture the audio alone, follow the steps below to switch to the Audio Capturing mode.

1. Press the INPUT SELECT button on the front panel to switch to the ANALOG IN mode.
The ANALOG IN LED will be lit.
2. Set the DIP switch 1 on the bottom to the other side from the current position.
Example: Move the Switch 1 to ON if it's currently in OFF position.

STAUS LED is lit, while the DIGITAL IN and ANALOG IN LEDs are unlit.
3. Play the audio data to capture.
4. Capture the audio data on your computer.

NOTE:

Switch to the Audio Capturing mode, only when the Deck Status from the application's point of view is "PLAY". Otherwise, the subsequent operations cannot be guaranteed.

In that event, please switch back to the normal mode, set the deck status "PLAY", and then switch to the Audio Capturing mode again.

Note that you can set the deck status "PLAY" in either of the following method.

- Press the PLAY button on the application
- Change to the Digital In mode by pressing the INPUT SELECT button on the ADV110 unit, and change back to the Analog In mode by pressing the button again.



Info

To switch back to the normal input mode, set the DIP switch 1 back to the original position.



Caution

If video signal is input during the Audio Capturing mode, the subsequent operations can not be guaranteed.



Caution

When the input source is paused or stopped in the Audio Capturing mode, it cannot be captured.

ADVC110

Advanced Digital Video Converter

Chapter 2

Using ADVC110

This chapter explains basic instructions for using the ADVC110.

Setting DIP switches

Use the DIP switches on the bottom of the unit to modify the ADV110's functionality. Make sure the power is turned off before you make any changes.

Table 1: DIP Switch Settings

No.	Mode	OFF	ON
1	Digital-in Reference Sync	Stream Sync	Fixed
2	Power-on Input Mode	Analog	Digital
3	Audio Mode	48kHz/16-bit	32kHz/12-bit
4	Locked Audio Mode	Locked	Unlocked
5	NTSC Setup Level(SW6=OFF)	0 IRE	7.5 IRE
	PAL/SECAM(SW6=ON)	PAL	SECAM
6	Video Format	NTSC	PAL

By default, DIP switches 1, 3, 4, 5 and 6 are in the **OFF** position, while DIP switch 2 is in the **ON** position.

* The DIP switch settings may differ depending on the region of shipment.

- **Digital-in Reference Sync Mode** - toggles between Stream Sync and Fixed modes. To make the Video Sync synchronized with the DV Stream Sync, set this Switch in the OFF position. If you set this switch in the OFF position and the color of the output video becomes black and white, set this switch in the ON position, making the Video Sync happen in the fixed timing.
- **Power-on Input Mode** - toggles between Analog In and Digital In modes when you first turn on the unit. If you primarily capture analog video, you should set this to the OFF position so the unit is in Analog In mode when you turn it on.
- **Audio Mode** - toggles between 48kHz/16-bit 2-channel audio and 32kHz/12-bit 4-channel audio. See Setting 4-channel mixing mode in the next section for more information.
- **Locked Audio Mode** - toggles between capturing locked audio or unlocked audio. If you are capturing a lot of long clips, you should leave this switch in the OFF position to make sure the audio stays locked to the video.
- **NTSC Setup Level** - toggles between 0 IRE (Japan NTSC) and 7.5 IRE (USA NTSC).
- **PAL/SECAM** - specifies PAL or SECAM, when the DIP switch 6 is in the ON position (set to PAL).
- **Video Format** - toggles between capturing NTSC and PAL video. The ADV110 is set to capture NTSC video by default.



Info

Input Analog SECAM signal will be captured in DV PAL signal. In this occasion, the color of the Analog output signal cannot be guaranteed. When you re-convert the captured DV signal to Analog signal, Analog PAL signal will be output, instead of Analog SECAM signal.

4-channel mixing mode

When encoding DV to analog in 32kHz mode, the unit can be set to either:

1. Use the main audio channel (48kHz/16bit 2-channel mode or 32kHz/12bit 4-channel mode)
2. Mix main and sub channel at 50% each. (4-channel mixing mode)

Setting 4-channel mixing mode

1. Set DIP switch 3 to the ON position.
2. Press and hold the **Input Select** button when turning on the unit.
3. The **STATUS** LED is lit, when the ADVC110 is in Digital IN mode.

Bus power

If you connect the ADVC110 unit to your computer with only the 6-pin FireWire cable, it can be powered by the FireWire port and doesn't need the AC Adapter.

If the ADVC110 unit is always connected to your system, it will automatically be turned on or off, whenever you start up or shut down your computer.

Power to the ADVC110 must be supplied through the AC Adapter if the ADVC110 is connected to the computer with an analog cable or a 4-pin FireWire cable.

Macrovision detection

When Macrovision signals are detected by the ADVC110:

- The brightness and contrast for both analog and DV output are lowered.
- The Status light blinks

DVCAM support

When you are connecting to a DVCAM unit, set DIP switch 4 to the OFF position to set the ADVC110 to Locked Audio Mode.

Video signals from game consoles

If you are capturing from a video source with irregular video signals, such as game consoles, you may hear audio noise in the captured video. If this happens, try setting DIP switch 4 to the ON position so the audio is unlocked.

Using with Grass Valley DV products

* AC adapter (optional) is required.

When the ADVC110 is connected to your Grass Valley DV products, use the following setting.

1. When the ADVC110 is connected to a Grass Valley DV product:
Set the input mode according to the input signal.
2. When a Grass Valley DV product is connected to a DV IN/OUT port, and a DV camera to the other DV IN/OUT port:
Set the input mode to DIGITAL IN.



Info

When the ADVC110 is connected to your computer with the other cable than a FireWire cable (6 pin - 6 pin), use the AC adapter to supply power.

有毒有害物质含有表 (This information is applicable for People's Republic of China only.)
 产品中有毒有害物质或元素的名称及含量

部件名称	有毒有害物质或元素					
	铅 Pb	汞 Hg	镉 Cd	六价铬 Cr(VI)	聚溴联苯 PBB	聚溴二苯醚 PBDE
电缆	○	○	○	○	○	○
外壳	○	○	○	○	○	○
焊锡	○	○	○	○	○	○
电路板	○	○	○	○	○	○
电子元件	×	○	○	○	○	○

○：表示该有毒有害物质在该部件所有均质材料中的含量均在SJ/T11363-2006标准规定的限量要求以下。
 ×：表示该有毒有害物质至少在该部件的某一均质材料中的含量超出SJ/T11363-2006标准规定的限量要求。

